



**MODEL HRFS FR**

**Face-Mounted Fountain**



These fountains are certified to NSF/ANSI 61.

**GENERAL**

Face-mounted fountain, one-piece, non-corrosive stainless steel number 300 series with brushed satin finish. Contour-formed basin with rounded corners and edges reduces splatter, insures proper drainage and prevents standing waste water.

**FREEZE-RESISTANT VALVE SYSTEM**

Freeze-resistant system features box that installs behind non-freezing wall for housing water connection from the stop to the strainer.

**BUBBLER**

Vandal-resistant bubbler is one-piece, chrome-plated, and is secured to fountain with anti-rotation mounting system. Unit has integral hood guard design to prevent contamination from other users, airborne deposits and tampering.

**PUSHBUTTON ACTUATION MECHANISM**

Self-closing, vandal-resistant pushbutton does not require grasping or twisting.

**AUTOMATIC STREAM HEIGHT REGULATOR**

Self-closing assembly is located inside unit to prevent tampering. Unit resists corrosion and liming. A constant stream height is automatically maintained under line pressures that vary from 20 to 105 psi.

**INLET STRAINER**

Easily cleaned in-line strainer screen traps particles of 140 microns or larger before they enter the waterway.

**WATER INLET**

3/8" O.D. Tubing into freeze-resistant box

**DRAIN OUTLET**

1-1/4" waste outlet located in freeze-resistant valve system.

**SUGGESTED SPECIFICATIONS**

Fountain shall include pushbutton on the front, contour-formed basin to eliminate splashing and standing water, and shall have rounded corners and edges. Projector shall be chrome-plated vandal-resistant type with integral hood guard and anti-squirt feature. The manufacturer shall certify the unit to meet the requirements of NSF/ANSI 61, and the Safe Drinking Water Act.

Note: Continued product improvement makes specifications subject to change without notice. See Halsey Taylor website for most current spec sheet.



**Standard finish is Stainless Steel**

**Each HRFS FR consists of 2 cartons of the following:**

- Fountain, Panel and Misc. Parts
- Freeze-Resistant Valve System

**Service stop not included.**

**Shipping weight: 35 lbs.**

JOB NAME: \_\_\_\_\_  
 \_\_\_\_\_  
 \_\_\_\_\_

ENGINEER/CONTRACTOR NAME:  
 \_\_\_\_\_

APPROVAL: \_\_\_\_\_

DATE: \_\_\_\_\_



**HRFS FR**

**Freeze-Resistant  
Contour™ Face-Mounted  
Fountain**

(CONTINUED)

**MOUNTING INSTRUCTIONS**

Refer to diagrams for rough-in of freeze-resistant system and plumbing. For wall support required locations see installation instructions provided with fountain. Water supply and waste line are to be assembled as required. Final check for leaks and correct functions of fountain should be made. (For details see the installation instructions.)

**CAUTION - Fountain must be securely bolted to wall.**

**OPERATING PRESSURES**

Supply water-105 psi maximum

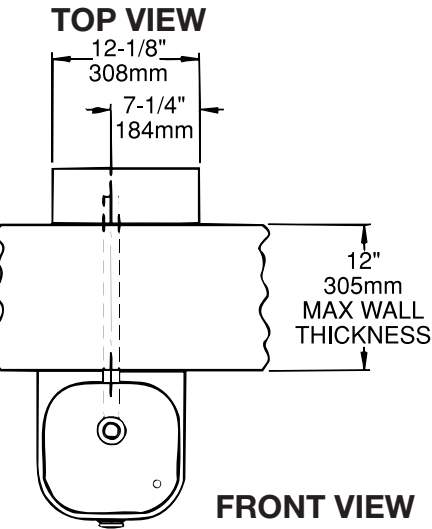

**WALL LAYOUT**

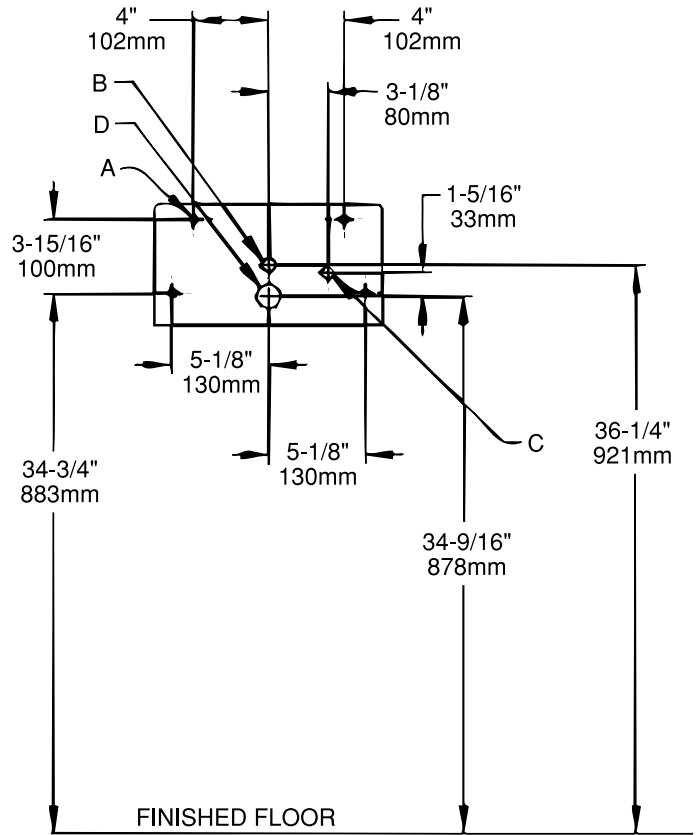

**SIDE VIEW**

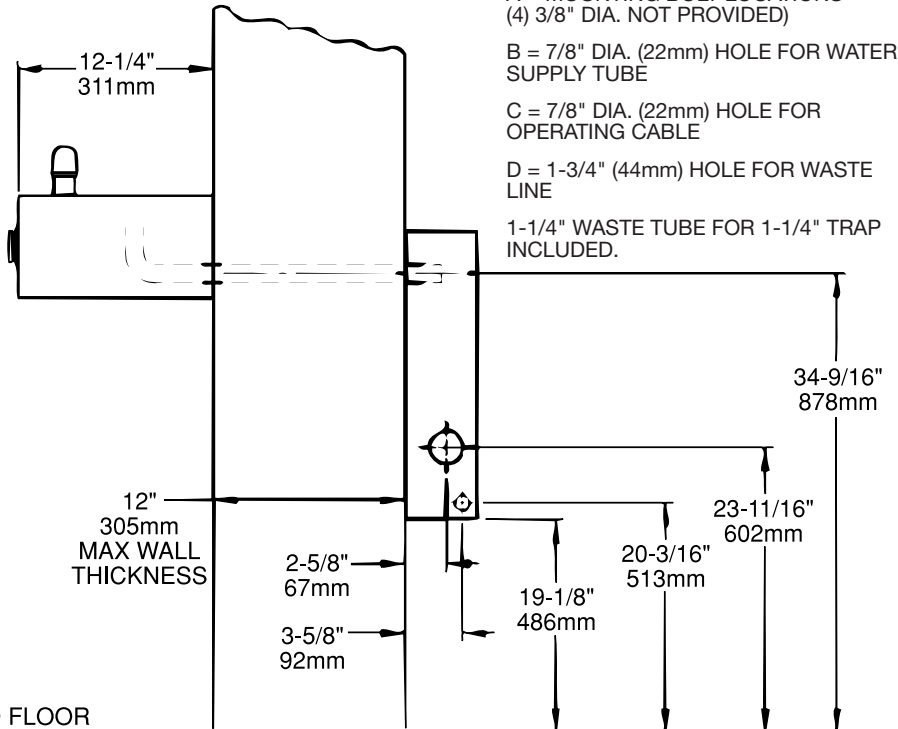

**LEGEND:**

- A = MOUNTING BOLT LOCATIONS (4) 3/8" DIA. NOT PROVIDED
- B = 7/8" DIA. (22mm) HOLE FOR WATER SUPPLY TUBE
- C = 7/8" DIA. (22mm) HOLE FOR OPERATING CABLE
- D = 1-3/4" (44mm) HOLE FOR WASTE LINE
- 1-1/4" WASTE TUBE FOR 1-1/4" TRAP INCLUDED.

NOTE: A service supply stop must be installed at the fountain inlet line.  
Important: Freeze-resistant box must be installed on interior non-freezing wall.